



INSTRUCTION MANUAL

LARGE GARDEN TROLLEY

Model No: THLGT -- Product No: 193857001

ASSEMBLY REQUIRED

SAVE THESE INSTRUCTIONS

SPARES & SUPPORT: 01793 333212

Please read & understand this manual, paying attention to the safety instructions, before use.
The manufacturer reserves the right to change the product specification and livery according to
continued product improvements.

Images used are for illustration purposes only and may differ from the actual product.

CONTENTS

SPECIFICATION

IMPORTANT INFORMATION

GENERAL SAFETY INSTRUCTIONS

SET UP & PREPARATION FOR OPERATION

ASSEMBLY

MAINTENANCE & STORAGE

TROUBLE SHOOTING

PARTS DIAGRAM & LIST

WARRANTY

ASSEMBLY IS REQUIRED – TWO PERSON'S

This product requires assembly before use. See the "Assembly" section for instructions. Because of the weight and size of the Trolley, it is recommended that a minimum of TWO adults be present to assist with the assembly.

If you require any assistance with regards to the contents or operation of your machine, please contact us:

TEL: 01793 333212

**EMAIL: customerservice@handydistribution.co.uk
(MON – FRI 8.00AM TO 5.30PM EXCL. BANK HOLIDAYS)**

SPECIFICATION

The manufacturer reserves the right to change the product specification and livery according to continued product improvements.

Model	THLGT
Product No.	193857001
Load Capacity (kgs)	350
Overall Dimensions (cm)	140(L) 64(W) 65(H) (exc. draw bar handle)
Internal Bed Dimensions (cm)	119(L) 58(W) 30(H)
Wheel Diameter (mm)	107.5
Tyre Size	13 x 5.00-6
Tyre	Puncture-less

IMPORTANT INFORMATION

INTENDED USE

The Large Garden Trolley is designed for use in private gardens and primarily used around **GRASS OR LAWN AREAS**, but not in public facilities, parks or sports grounds and not for agricultural or forestry use. Never exceed the rated load capacity of 350kg.

This is a garden trolley, therefore extended use over abrasive surfaces (e.g. concrete, tarmac etc.) could cause premature wear on the trolley tyres. Commercial or industrial environments are not recommended.

When operating with a tractor, do not exceed 10mph.

Generally acknowledged accident prevention regulations and enclosed safety instructions must be observed. Only perform work described in these instructions for use, any other use is incorrect. The manufacturer will not assume responsibility for damage resulting from such use.



WARNING

Read this instruction manual carefully before operating this machine. Make sure that you are familiar with the controls and properly operate the machine. Following these instructions can reduce the risk of personal injury.

IF NOT USED PROPERLY THIS MACHINE CAN BE DANGEROUS!

This machine can cause serious injury to the operator and others, the warning and safety instructions must be followed to ensure reasonable safety and efficiency in using this product. The operator is responsible for following the warning and safety instructions in this manual and on the machine. Never use the product unless the components are correctly positioned and operational.

TRAINING









Read the instructions carefully: Be familiar with the controls and the proper use of the equipment. Never allow children or people unfamiliar with these instructions to use the product.

Local regulations can restrict the age of the operator.

Keep in mind that the operator or user is responsible for accidents or hazards involving the machine that occur to other people or their property.

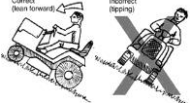
GENERAL SAFETY INSTRUCTIONS

Read and understand the owner’s manual and labels affixed to the product. Learn its application and limitations as well as the specific potential hazards. Retain these instructions for future reference. The operator is responsible for following the warnings & instructions in this manual and on the product.

	<p>Read & understand the operator’s manual before using the machine. Failure to follow instructions could result in death or serious injury.</p>		<p>DANGER Pinch points can cause personal injury.</p>
	<p>Wear gloves to protect your hands during assembly.</p>		<p>Check your machine before using. Keep guards in place and in working order. Frequently check to see that foreign objects are removed before using. Replace damaged, missing or failed parts before using it.</p>
	<p>Be careful when using on slopes. Do not operate on inclines greater than 15°. It is advised to manually or with your tractor, pull up or down the incline.</p>		<p>Safety alert symbol. Used to alert you to potential personal injury hazards. Obey all safety messages that follow this symbol to avoid possible injury.</p>
 <p>DANGER</p>	<p>Indicates an imminently hazardous situation which, if not avoided, will result in serious injury.</p>	 <p>WARNING</p>	<p>Indicates a potentially hazardous situation which, if not avoided, could result in serious injury.</p>
 <p>CAUTION</p>	<p>Indicates a potentially hazardous situation which, if not avoided, may result in minor or moderate injury.</p>	<p>CAUTION</p>	<p>Used without the safety alert symbol, indicates a potentially hazardous situation which, if not avoided, may result in property damage.</p>

STAY ALERT

Do not operate the machine while under the influence of drugs, alcohol, or any medication that could affect your ability to use it properly. Do not use this machine when you are tired or distracted from the job at hand. Be aware of what you are doing at all times. Use common sense.

AVOID DANGEROUS CONDITIONS

Make sure there is adequate surrounding workspace. Cluttered areas invite injuries. Keep your work area clean with sufficient light. Keep the area around the machine clear of obstructions, grease, oil, rubbish & other debris which could cause persons to fall onto moving parts.

INSPECT YOUR MACHINE

Check all bolts, nuts & screws for tightness before each use, especially those securing guards & drive mechanisms. Vibration during use, may cause these to loosen. Replace damaged, missing or failed parts before using. Warning labels carry important information. Replace any missing or damaged warning labels.

CRUSH AND CUT HAZARDS

Always keep your hands and feet clear from moving parts while operating the equipment. Always keep the work area clean and clear when operating.

DRESS PROPERLY

Do not wear loose clothing or jewellery (rings, wrist watches), which can be caught in moving parts.

CONDITIONS

We recommend the machine is not used during winds. This may affect the spreading pattern.

DO NOT OVERREACH

Keep proper footing and balance. Never stand on the machine. Serious injury could occur if the machine is tipped or if the moving parts are unintentionally contacted. Do not store anything above or near the machine, where anyone might stand on the machine to reach them.

AVOID INJURY FROM UNEXPECTED ACCIDENT

Keep hands & feet out of the way of all moving parts. Do not place any part of your body or any tool e.g. in moving parts of the machine during operation.

DO NOT FORCE TOOL

Always work within the rated capacity. Do not operate for a purpose for which it was not intended.

MAINTAIN YOUR MACHINE WITH CARE

Clean the machine immediately after use. Keep the machine clean to ensure it operates to its full & safest performance. When maintaining this machine, only the manufacturer's original replacement parts should be used. The use of non-original manufacturer parts may invalidate your warranty.

PROTECT THE ENVIRONMENT

Take left over materials to an authorised collection point or follow the stipulations in the country where the machine is used. Do not discharge into drains, soil or water.

STORE IDLE EQUIPMENT

When not in use, the machine should be stored in a dry location. Keep the machine away from children and others not qualified to use it.

TOWING

Do not exceed the equipment maximum load capacity of 350kg.

Do not try to carry loads that make the Trolley unstable.

Avoid large holes and ditches when using the Trolley.

Be careful when operating on steep gradients (hills) the Trolley may tip over.

Only tow with recommended vehicles (Lawn/Garden Tractors and ATVs).

Always operate at a reduced speed in rough terrain, along creeks, ditches and on hillsides.

Do not operate close to creeks, ditches and public roads.

To avoid personal injury and/or equipment damage **DO NOT EXCEED 10 MPH.**

Always use caution when loading and unloading the Trolley.

Always secure and lock the Trolley to the vehicle hitch before operating

SET UP & PREPARATION FOR OPERATION

Follow the operating instructions step-by-step and use the pictures provided as a visual guide to easily assemble the machine.

Please ensure that you have all the necessary parts, before commencing with the assembly. Parts lists are supplied towards the back of this manual.

In the unlikely event that you are missing a component, please do contact us Tel: 01793 333212 or Email: customerservice@handydistribution.co.uk for assistance.

ASSEMBLY

STEP 1

Turn the trolley Bed (1) upside down so that the underside is facing up.

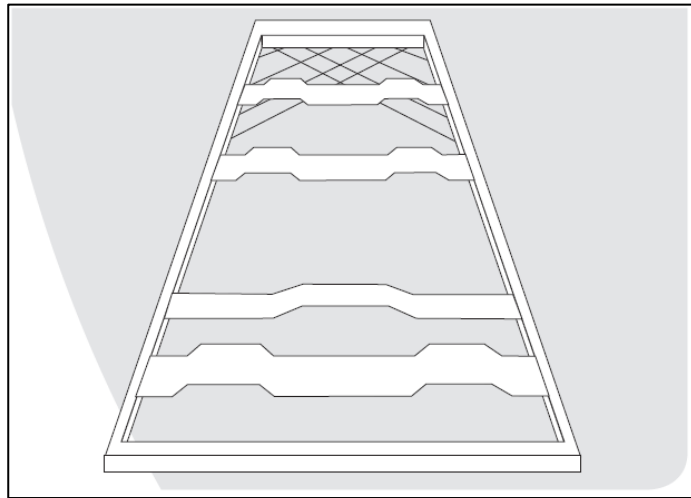

STEP 2

Attach the Rear Axle Support to the Bed using two Carriage Support Bolts, Washers & Nuts (18) x2.

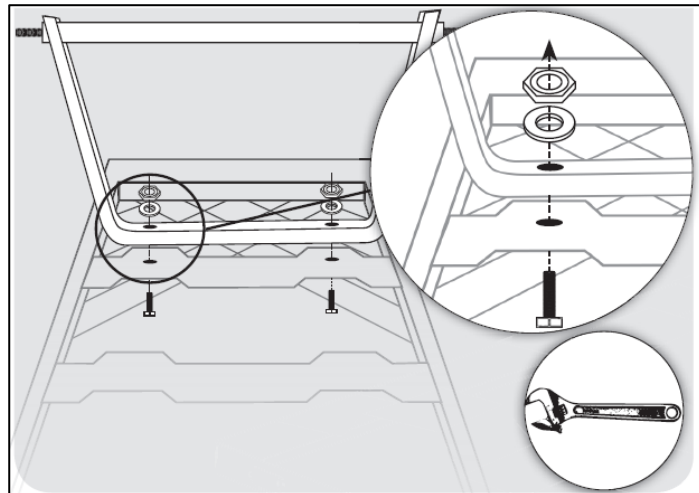

Place the Right (7) and Left (8) Rear Axle Braces onto the Rear Axle Support

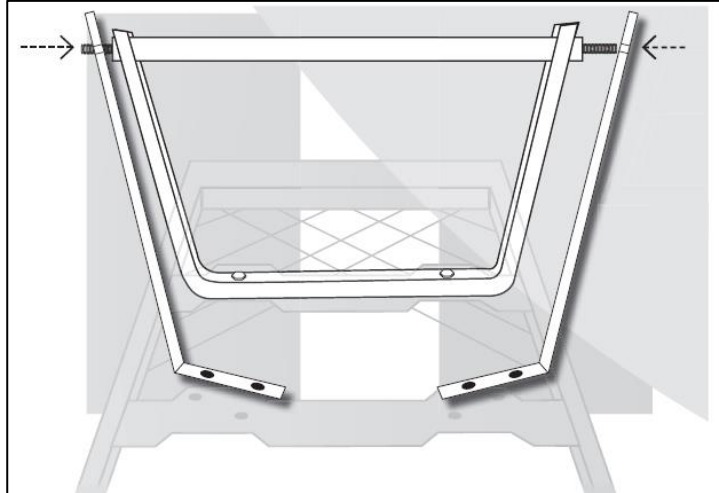

Attach using Rear Axle Braces using four Carriage Support Bolts, Washers & Nuts (18) x4.

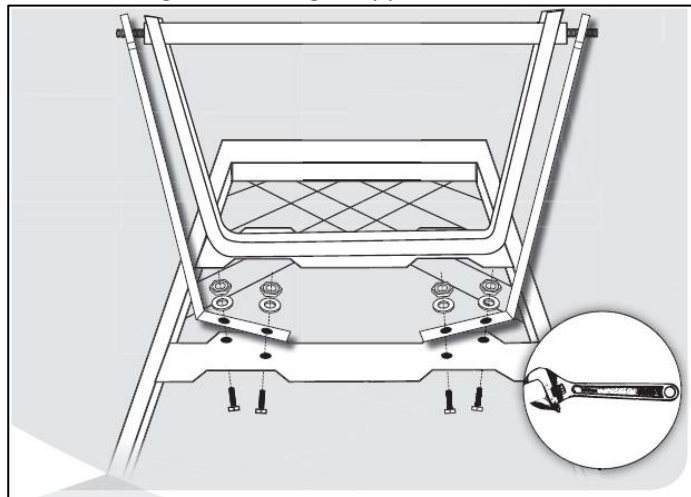

STEP 3

Attach the Front Axle Support (9) to the Bed using 2x Carriage Support Bolts, Washers & Nuts (18).

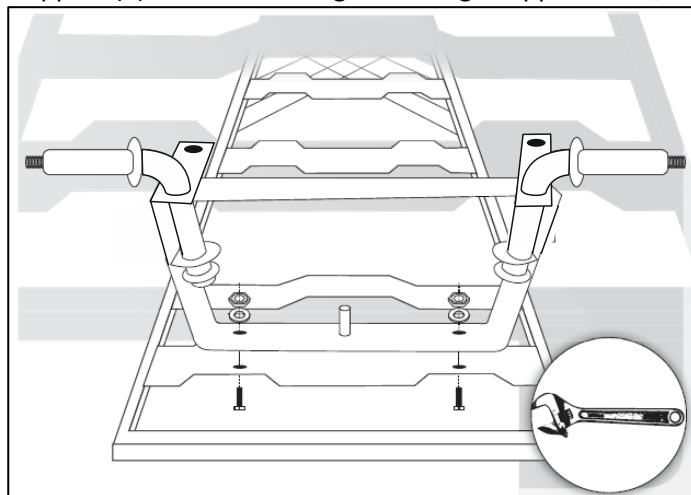

STEP 4

Attach the Steering Link Connector (12) to the Front Axle Support arms, using 2x Bolts, Washers and Nuts (19). The connector should sit over the axle as pictured.

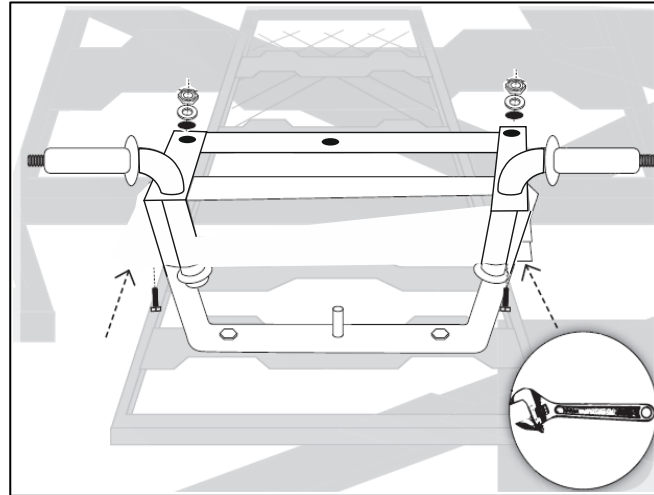

STEP 5

Position the Central Front Axle Brace (10) to the Front Axle Support

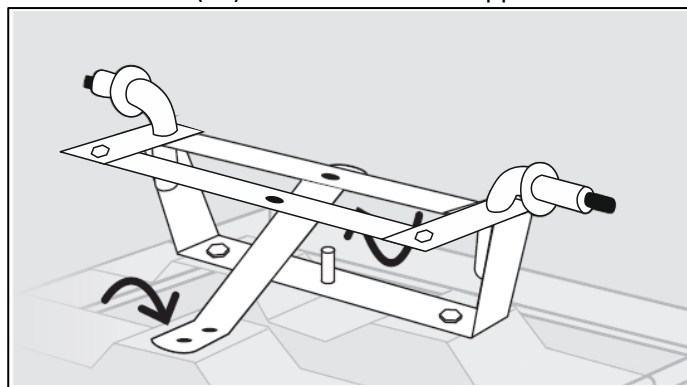

Fix the Central Front Axle Brace (10) to the Bed using 2x Carriage Bolt, Washer & Nut (18).

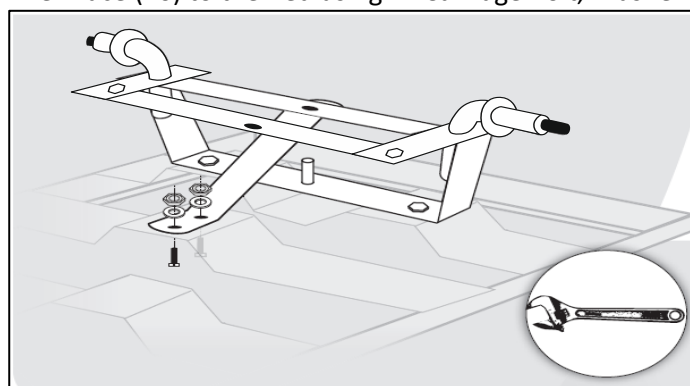

STEP 6

Slot the stepped arm of the Yoke (11) onto the protruding leg of the Front Axle Support (9).

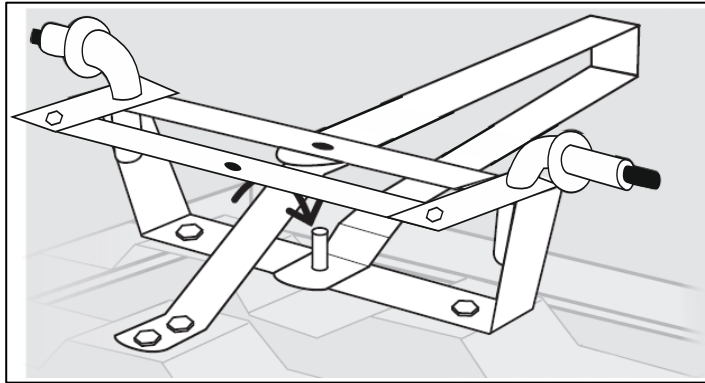

Position the straight arm of the Centre Front Axle Brace (10) between the Yoke (11) & Front Axle Support (9).

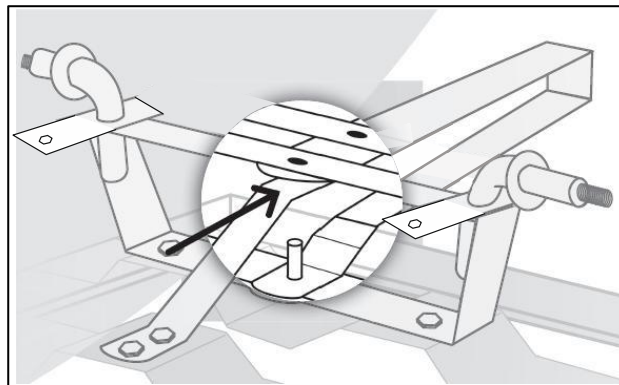

STEP 7

Fix the Yoke (11) & Centre Front Axle Brace (10) to the Front Axle Support (9) using Bolt, Washer & Nut (19).

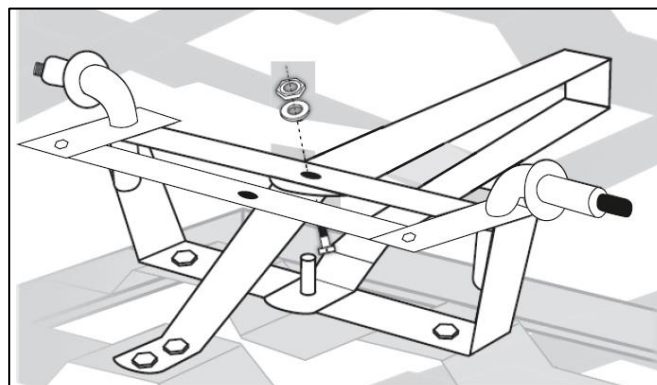

Fix the Steering Link Connector (12) to the Yoke (11) using Carriage Bolt, Washer & Nut (18).

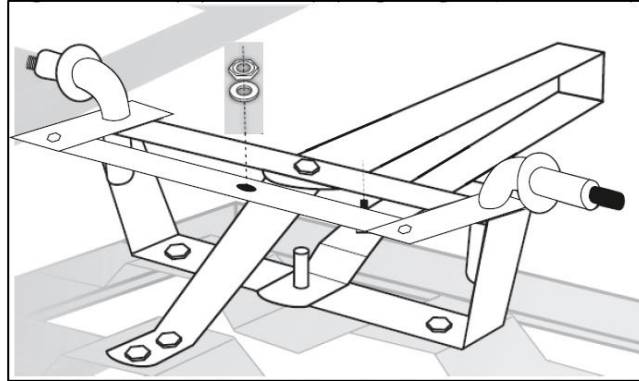

Slide the Large Washer (23) over the Front Axle Support (9) protruding leg and slide the Split Pin (16) through the hole. Split open the Pin legs to secure.

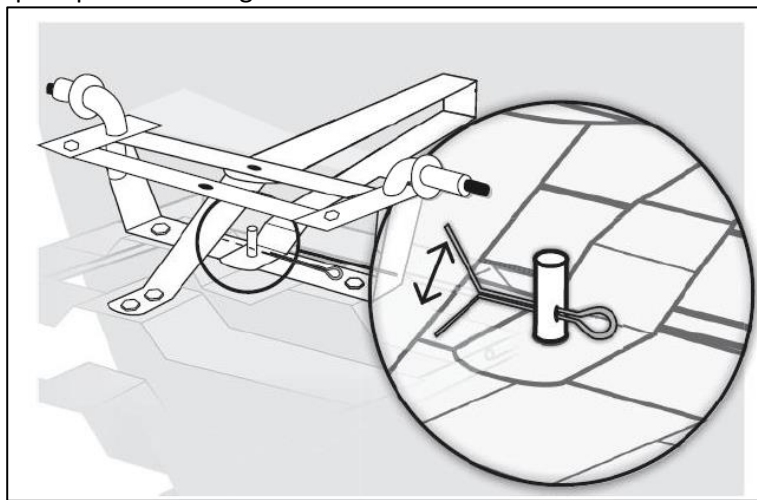

STEP 8

- Attach the Pull Adapter (13) to the Yoke (11) & Pull Handle Assembly (14 & 15). Align the holes in the handle assembly, Pull adaptor and the Yoke.
- Secure using the Pull Handle Bolt, Washer and Nut (21).
- If you wish to attach the trolley to a garden tractor, remove the end of the Pull Handle by undoing the R-Clip and removing the Pull Bolt, and attach the tow hitch directly to the tractor using the same R-Clip & Pull Bolt.



STEP 9

- Slide the Axle Sleeve (24) onto the axle.
- Slide the Wheel (5) onto the axle.
- Secure using a Wheel Washer (17) and a Wheel Nut (25) on to the axle. Do not over tighten; this may cause the wheel to not rotate. Repeat with the remaining wheels.



STEP 10

Turn the Trolley over onto its wheels (DO NOT try and lift on your own, ask for assistance!)

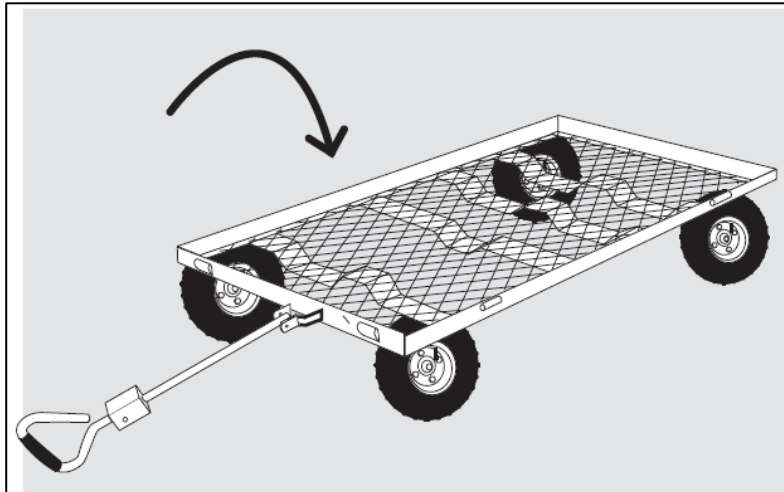

STEP 11

Attach the two Side (2), Front (3) & Rear (4) Panels to the Bed, using the R-Clip (20) (Two for each Panel).

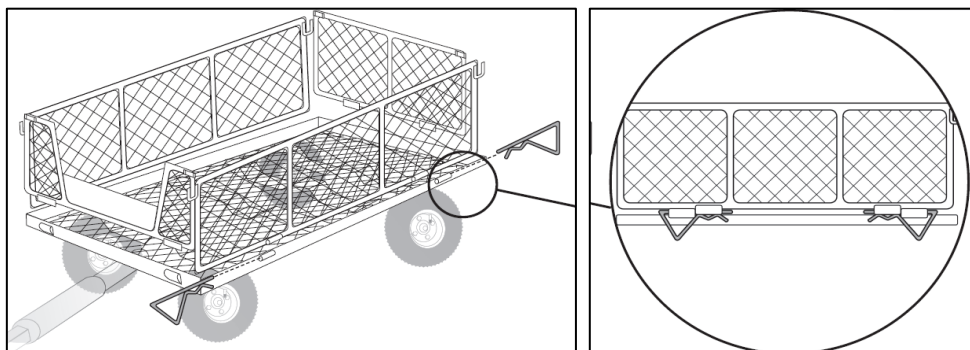

STEP 12

Locate the Side Lock Handles (22) through the tabs on the top right and left of the front and back Side Panels, ensuring that the threaded end faces inwards towards each other. Lift the Side Panels into position and secure the nut. Securely tighten all nuts before use.

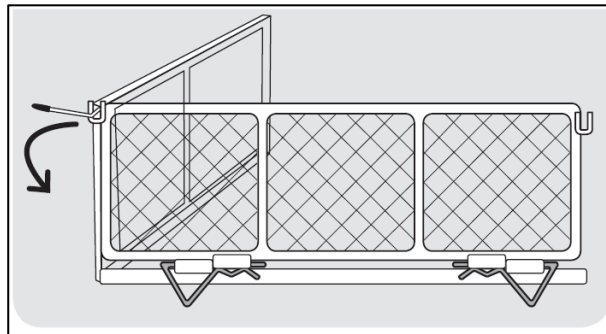

MAINTENANCE & STORAGE



WARNING!

Repairs and maintenance work other than those described within this instruction manual may be performed only by an authorised service agent.

MAINTENANCE

Users of this product should only undertake actions described in this manual, unless otherwise instructed by the manufacturer. When repairing the product, always use approved replacement Handy Parts or those which are technically identical. Using high quality replacement parts avoid the risk of accidents, damage to the product and invalidating the manufacturer's warranty.

STORAGE

Never allow carried material to remain in the Trolley for extended periods of time. For years of trouble free service, make sure the Trolley is clean and dry before storing.

Store in a dry protected area away from sunlight and severe weather in winter months.

If storing for an extended period, grease the axles and wheel bearings on the Trolley.

TROUBLESHOOTING



WARNING!

If the product does not perform properly, makes unusual sounds, or any other irregularity or malfunction occurs, do not attempt to repair the product by yourself. Please contact customer services or your local authorised service dealer for advice.

NEED ASSISTANCE

For Spares or Support of your Handy product, please contact us:

Tel: 01793 333212

Email: customerservice@handydistribution.co.uk

Monday to Friday 8.00am to 5.30pm (excl. Bank Holidays)

PARTS LIST & DIAGRAM

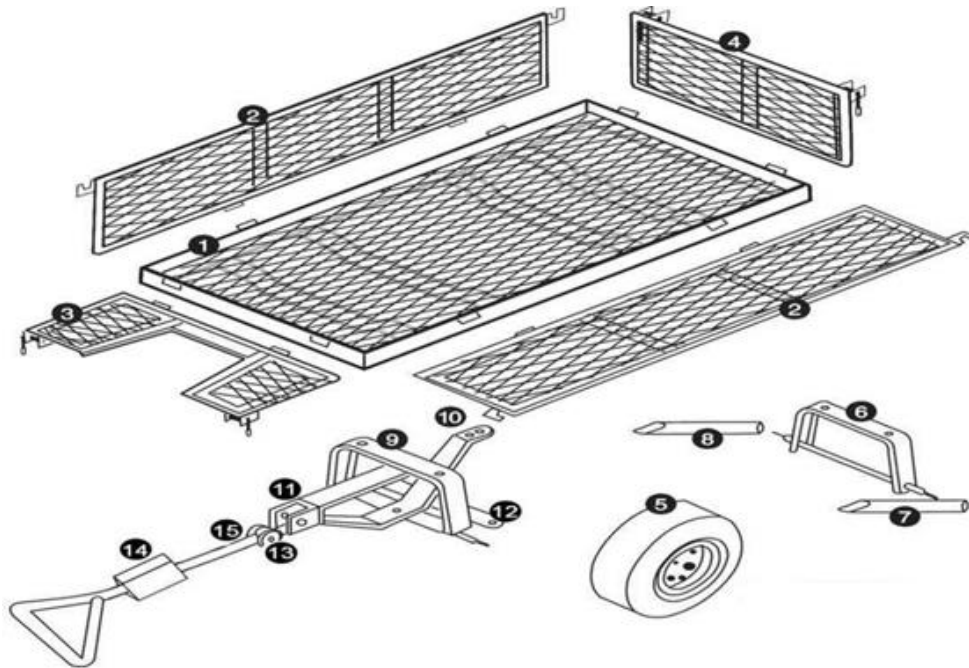

NOTE: Parts Lists are supplied for information purposes only, not all parts are stocked individually & we recommend you contact our Spares Team on 01793 333212 for expert advice.

Item No	Part No.	Description	Quantity
1	TH215-1-1	Bed	1
2	TH215-2-2	Side Panel	2
3	TH215-3-3	Front Panel	1
4	TH215-4-4	Rear Panel	1
5	TH215-5-5	Wheel Assembly	1
6	TH215-6-6	Rear Axle Support	1
7	TH215-7-7	Right Rear Axle Brace	1
8	TH215-8-8	Left Rear Axle Brace	1
9	TH215-9-9	Front Axle Support with Axles	1
10	TH215-10-10	Central Front Axle Brace	1
11	TH215-11-11	Yoke	1
12	TH215-12-12	Steering Link Connector	1
13	TH215-E2-13	Pull Adaptor	1
14	TH215-14-14	Pull Handle	1
15	TH215-15-15	Lower Pull Handle	1

Item No	Part No	Description	Image	Quantity
16	TH215-A1-16	Split Pin - 3.0x50		1
17	TH215-B1-17	Wheel Washer 6		4
18	TH215-C-18	Carriage Support Bolt, Washer & Nut - M8x15mm		10
19	TH215-A4-19	Bolt, Washer & Nut - M6x16mm		3
20	TH215-D-20	R-Clip - 40x105		8
21	TH215-E1-21	Bolt, Washer & Nut for Lower Pull Handle - M8x60		1
22	TH215-F-22	Panel Lever		4
23	TH215-A2-23	Large Washer 8		1
24	TH215-B3-24	Wheel Axle Sleeve - 19x16mm		4
25	TH215-B2-25	M12 Wheel Lock Nut		4
26	TH215-A3-26	Bolt, Washer & Nut - M6x20mm		1
27	TH215-27-27	Pull Bolt & R-Clip for Top Handle		1

GJ HANDY & CO LTD USER WARRANTY POLICY

Users Statement of Warranty

Each new machine is warranted against defective material or assembly of material under normal usage. The warranty applies to the original purchaser and covers faulty parts and the labour involved in replacing and repairing those parts, which are of original manufacture.

Period of Warranty

Webb (excludes Electric Handheld)

Webb Pro

Sanli Engine

- a) 2 years from the original date of sale to the first domestic user.
- b) 90 days from the original date of sale to the professional/commercial user.
- c) 90 days from the original date of sale when used for hire.
- d) A reduced warranty period of 90 days applies to those items which are subject to normal wear and tear (e.g. but not limited to wheels, tyres, cutter bars, cylinders, cutting blades, blade boss, belts, cables, nylon line & spool, collection bags, spark plugs).
- e) Engines are supplied with a separate warranty to the machine. The engine manufacturers warranty statement which will be supplied within the engine instruction manual. All enquiries and warranty repairs should be discussed with the engine manufacturer or approved warranty repair dealer.
- f) 90 days from the original date of purchase for Replacement Spare Parts (unless normal wear & tear component, which are covered for 30 days).
- g) All machines' must be serviced within the first 12 months from the original date of purchase to comply with the warranty, failure to do so will invalidate the 2nd year of the warranty.

All warranty repairs must be undertaken by an authorised service dealer. These dealers have been accredited by GJ Handy & Co Ltd and agree to only use genuine parts and follow our repair procedures.

Webb Electric Handheld

Handy

Mowerland

Q-Garden

- a) 1 year from the original date of sale to the first domestic user.
- b) 90 days from the original date of sale to the professional/commercial user.
- c) 90 days from the original date of sale when used for hire.
- d) A reduced warranty period of 90 days applies to those items which are subject to normal wear and tear (e.g. but not limited to wheels, tyres, cutter bars, cylinders, cutting blades, blade boss, belts, cables, nylon line & spool, collection bags, spark plugs).
- e) Engines are supplied with a separate warranty to the machine. The engine manufacturers warranty statement which will be supplied within the engine instruction manual. All enquiries and warranty repairs should be discussed with the engine manufacturer or approved warranty repair dealer.
- f) 90 days from the original date of purchase for Replacement Spare Parts (unless normal wear & tear component, which are covered for 30 days).

All warranty repairs must be undertaken by an authorised service dealer. These dealers have been accredited by GJ Handy & Co Ltd and agree to only use genuine parts and follow our repair procedures.

GJ HANDY & CO LTD USER WARRANTY POLICY

Not covered by this warranty

- a) The warranty policy does not cover any depreciation or damages caused by ordinary wear, rusting or corrosion, lack of correct maintenance or operation, misuse, abuse, lack of transportation or accident.
- b) The warranty policy does not cover any costs necessary for the standard periodic maintenance services instructed by the operator's manual, or service parts replacement which would include oil, filters, tyres, belts, brake linings, fuses, blades, seals and other service parts unless it can be proven that the item has evidence of faulty manufacture.
- c) The warranty policy will not cover failure or damage caused as a result of parts or accessories being modified without the written approval of GJ Handy & Co Ltd.
- d) The warranty policy will not cover the unit if non-genuine parts have been fitted and as a result damage has occurred to the unit.
- e) The warranty policy is non-transferable and is only applicable to the original purchaser.

Disclaimer

- a) This warranty is only a remedy for defect of products. GJ Handy & Co Ltd will never warranty in terms of the merchantability or the fitness for a particular purpose.
- b) No person is authorised to make any warranties, representations or promises, expressed or implied, on behalf of GJ Handy & Co Ltd, or to modify the terms conditions or limitation of this warranty policy in any way.
- c) Neither GJ Handy & Co Ltd nor any company affiliated with GJ Handy & Co Ltd shall be liable in any event or manner whatsoever for incidental or consequential damages or injuries, including, but not limited to, loss of crops, loss of profit, out of pocket expenses or profits, rental of substitute equipment or other commercial losses.

General

- a) Most warrantable failures show up within the first few weeks of use. These failures are usually straightforward and warranty assessment is relatively easy.
- b) Failures relating to cutter decks and belts need careful investigation, as the cause may not always be straightforward. Look for damage to blades and pulleys especially when the cutter belt or blade boss have snapped or cracked as this could be due to impact damage.
- c) Customers should always refer to the operator/instruction manual when any disputed problem arises, you will find most areas covered within the manual.

For spares or support of your handy product,
please contact us:

Tel: 01793 333212

Email: customerservice@handydistribution.co.uk

(Mon – Fri 8.00am to 5.30pm excl. Bank Holidays)

To see our range of garden machinery & equipment visit:

www.thehandy.co.uk

Making gardening easier & affordable since 1938

Distributed by Handy Distribution, Murdock Road, Dorcan, Swindon, SN3 5HY